

# Validation progresses of the Voltage Holding Prediction Model at the High Voltage Padova Test Facility HVPTF

A. De Lorenzi, N. Pilan, A. Pesce and E. Spada

Consorzio RFX – Associazione EURATOM-ENEA per la Fusione  
Corso Stati Uniti 4, 35127 Padova, Italy

# TALK OUTLINE

- THE RESEARCH CONTEXT
  - The Neutral Beam Injector for ITER/NBTF
  - The High Voltage Test Facility HVPTF
- THE VOLTAGE HOLDING PREDICTIVE MODEL
  - Description
  - Validation
  - Discussion
- REVIEW OF THE MODEL PHYSICAL BASIS
  - Limits of the Cranberg - Slivkov breakdown mechanism
  - The Photoelectric Cascade Model
  - Discussion
- CONCLUSIONS AND FUTURE WORK

# THE RESEARCH CONTEXT

The Neutral Beam Injector for ITER/NBTf

- Development of the Neutral Beam Injector for ITER, necessary for Thermonuclear Plasma Ignition.
- The research program PRIMA to built the NBI has started in Padova in 2011 (I).

**PRIMA**  
Padova Research on ITER Megavolt Accelerator

**SPIDER**  
Source for Production of Ion of Deuterium Extracted from Rf plasma

- $P_{\text{beam}} = 16.5 \text{ MW}$
- $I = 40 \text{ A}$
- $V = 1 \text{ MV}$
- $T_{\text{pulse}} = 3600 \text{ s}$

**MITICA**  
Megavolt ITER Injector & Concept Advancement

**FACILITY COST**

- BLDS & INFR. 20 M€
- EXP. EQUIP. 100 M€

Mission of PRIMA SPIDER MITICA:

- To achieve the ITER HNBS *nominal parameters*
- Maximize the *reliability* of the injectors
- *Develop technologies* for the injectors
- *Optimise* the NBI operation
- Test *key remote handling* tools and procedures

} HV HOLDING IN VACUUM

# THE RESEARCH CONTEXT



The High Voltage Test Facility HVPTF

The High Voltage Padova Test Facility HVPTF is conceived as supporting lab<sup>1</sup> for the PRIMA Program for Vacuum HV voltage holding studies and technological developments. The lab main objectives are:

- Breakdown physics and modelling
- Voltage conditioning automation
- Surface treatments
- Acceptance/validation of components before installation inside the NBI accelerator
- Training for personnel

The HVPTF has two setups available; one for experiments up to 300 kV, the other up to 800 kV.

## 300 kV setup

- 2 PS Spellman  $\pm 150\text{kV}$ -8mA
- SS AISI 304 tank – 0.5 m<sup>3</sup>
- Vertical axis
- Max gap 35 mm
- Alumina feedthroughs
- One feedthrough movable
- P better than 10<sup>-6</sup> Pa

## 800 kV setup

- 2 PS Heinzinger  $\pm 400\text{kV}$ -1mA
- SS AISI 304 tank – 2.0 m<sup>3</sup>
- Horizontal axis
- Max gap 1000 mm
- Alumina feedthroughs
- feedthroughs fixed
- P better than 10<sup>-5</sup> Pa

<sup>1</sup>A. De Lorenzi, N. Pilan, M. Fincato L. Lotto, G. Pesavento, R. Gobbo: *HVPTF - The High Voltage Laboratory for the ITER Neutral Beam Test Facility*, Fusion Engineering and Design, Volume 86, Issues 6–8, October 2011, Pages 742-745

# THE RESEARCH CONTEXT

The High Voltage Test Facility HVPTF

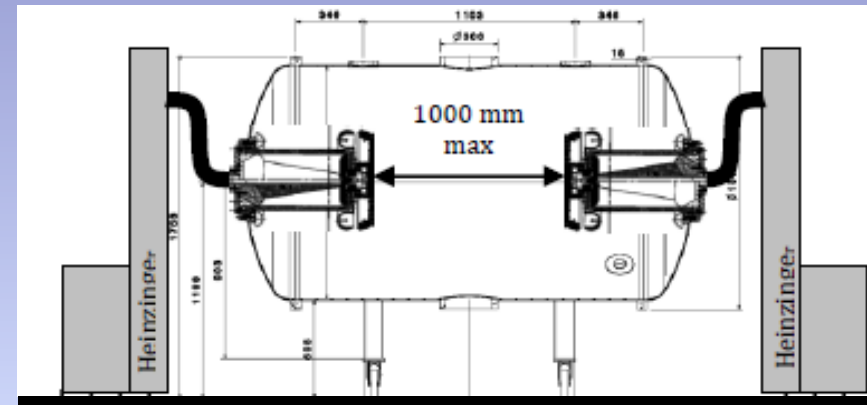
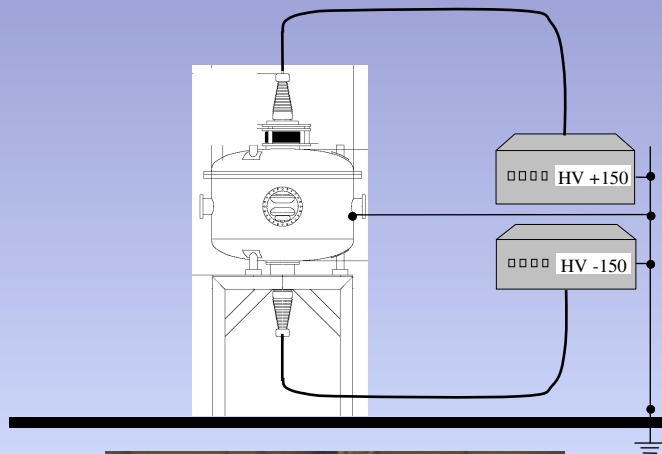

# THE VOLTAGE HOLDING PREDICTIVE MODEL<sup>1</sup>

Model purpose: to be a DESIGN TOOL, aimed to identify the breakdown probability associated to a given electrostatic configuration, taking into account

all-in-one

1) Shaped electrodes

2) Multi-electrodes multi-voltage system

3) Area effect

4) Polarity effect

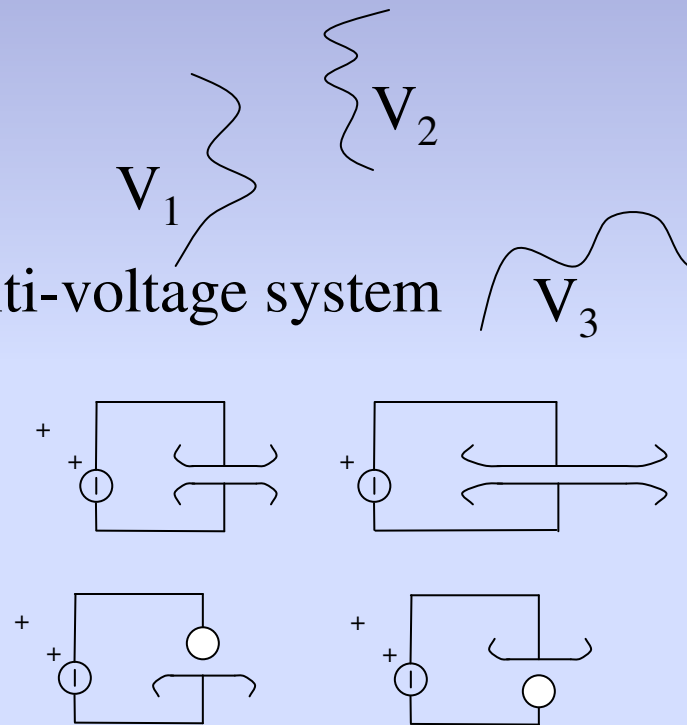

<sup>1</sup>Pilan, N.; Veltri, P.; De Lorenzi, A., *Voltage holding prediction in multi electrode-multi voltage systems insulated in vacuum* IEEE Transactions on Dielectrics and Electrical Insulation, Volume: 18 , Issue: 2 DOI 10.1109/TDEI.2011.5739461

# THE VOLTAGE HOLDING PREDICTIVE MODEL



Description

**Physical basis:** Slivkov<sup>1</sup> -Cranberg (S&C) Model. Clumps charged at the cathode are detached and fly accelerated to the anode. If the energy (qU) is sufficient, the clump vaporize and, under the effect of the anode electric field, there is a Paschen discharge across the vapour bubble, that leads to the gap breakdown. To each clump is thus associated the quantity:

$$W = E_K \cdot E_A^\alpha \cdot U; \quad \alpha = \frac{2}{3}$$

The breakdown can occur when  $W > W_l$  (clump mass and material)  
(for  $\alpha=0$ , parallel planes:  $U_{BD} \propto d^{0.5}$ )

$$N = \left( \frac{W - W_l}{W_0} \right)^m \left[ m^{-2} \right]$$

The number N of clumps per area unit that can produce breakdown is an monotonic increasing function of W; the 3-params Weibull distribution is the assumed function.

$$P = 1 - \exp \left( - \int_{A_K} \left( \frac{W - W_l}{W_0} \right)^m \cdot dA \right)$$

**Overall probability of breakdown.** The Integral extended to all the clumps emitting surfaces (cathodes in the S&C model)

**The model requires particle trajectory calculation in non relativistic motion. This is always true in case of clumps**

<sup>1</sup>Slivkov I.N. *Mechanism for electrical discharge in vacuum* .Soviet Phys. Techn. 2, 1928 (1957)

# THE VOLTAGE HOLDING PREDICTIVE MODEL

**First proof for validation:  
independence of measured  $W_1$ ,  
 $W_0$ , on electrodes geometry.**

- 5 different geometries tested, employing disk shaped, rogowsky profile AISI 304 electrodes:
  - D=108, 180 and 300mm
  - Surface finishing: Ra=0.10.14  $\mu\text{m}$
  - Thermal treatment: solution at 950° C for 2h (in air)
  - Polished by ultrasonic bath with acetone
  - gap d=5mm, 10mm, 12.5mm
- Use of automatic conditioning procedure
- Evaluation of  $W_0$  and m from P distribution ( $W_1$  set to 0)

Validation

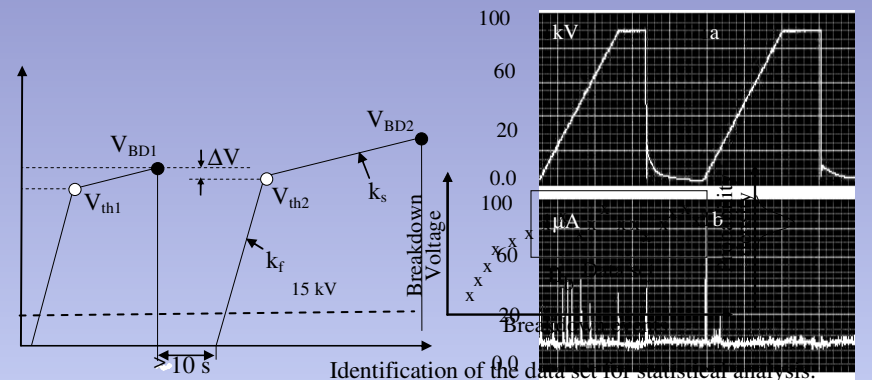

a Power Supply Voltage (one unit)  
b Power Supply current (one unit)  
c X Dose Rate  
d Pressure

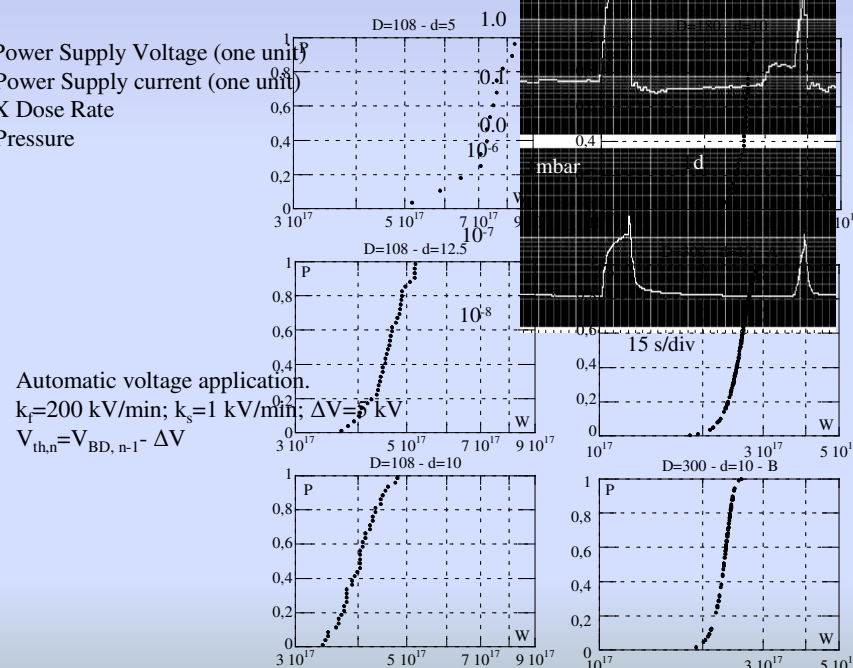

Automatic voltage application.  
 $k_f=200$  kV/min;  $k_s=1$  kV/min;  $\Delta V=5$  kV;  
 $V_{th,n}=V_{BD, n-1} - \Delta V$

Voltage breakdown probability plots for the parallel plane electrodes against  $W=U^{8/3}/d^{5/3}$



# THE VOLTAGE HOLDING PREDICTIVE MODEL

Validation

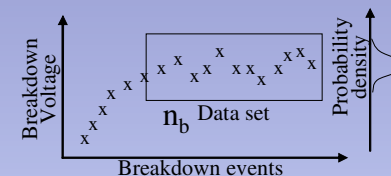

Identification of the data set for statistical analysis.

## Measured Voltage breakdown probability distribution

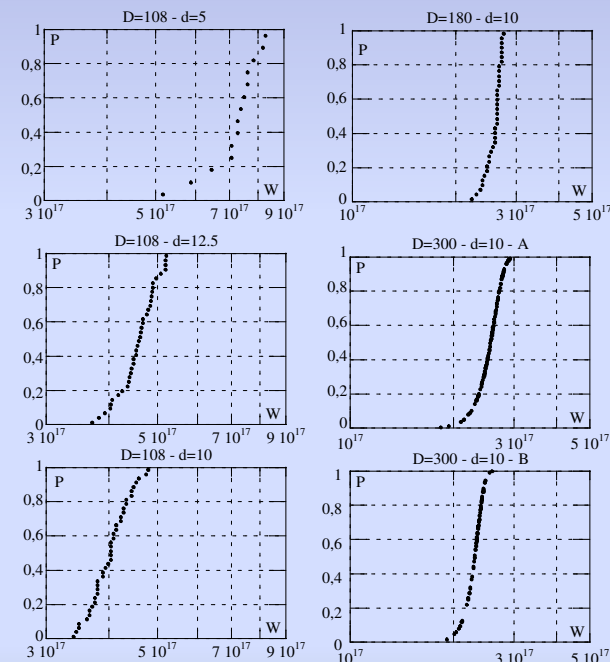

Voltage breakdown probability plots for the parallel plane electrodes against  $W=U^{8/3}/d^{5/3}$

## Results

- Only yellow data considered valid
- Comparison with very similar experiment in literature (sky blue)
- Fair agreement, even if not fully satisfactory
- Consistency with results in literature, apart the longest gap.

Source	$p \cdot 10^{-6}$ [mbar]	D [mm]	d [mm]	U [kV]	m [-]	$W_0 \cdot 10^{17}$ [V <sup>8</sup> m <sup>-5</sup> ] <sup>1/3</sup>
1	0.05	108	5.0	182	11.8	4.4
1	0.05	108	10.0	230	12.0	3.0
1	0.05	108	12.5	270	14.0	3.4
1	0.1	180	10.0	190	28.2	2.4
1	0.05	300	10.0	192	14.0	2.4
1	0.05	300	10.0	177	20.0	2.0
2	1.33	200	10.0	200	17	2.3
2	1.33	200	30.0	400	17	2.5
2	1.33	200	40.0	500	17	2.8
2	1.33	200	100.0	650	17	1.2

1-Data from HVPTF campaign.

2- Data from F. Rohrbach "Isolation sous Vide", CERN report 71-5, (1971)

## Second proof for validation: breakdown voltage prediction.

- Averaging the measured values of  $W_0$  and  $m$ :  $W_{0-ave}=2.8 \cdot 10^{17}$ ;  $m_{ave}=17$ ; Measurement and simulation of sphere-disk geometry;  $D_{disk}=180\text{mm}$ ;  $\Phi_{sphere}=40\text{mm}$ ;  $d_{gap}=10\text{mm}$ 
  - Sphere=cathode
  - Sphere=anode

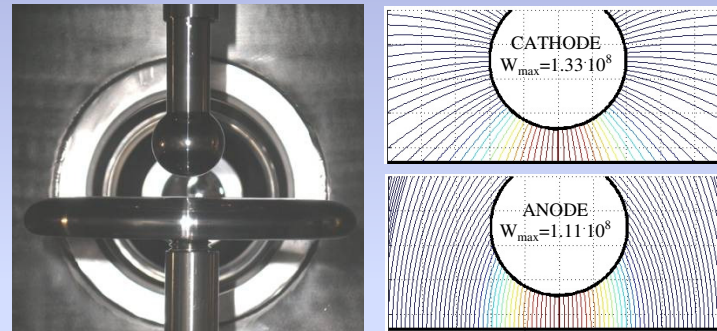

The Sphere-Plane configuration. The trajectories are colored as a function of  $W$ : the higher the  $W$ , the warmer the color.  $W_0=2.8 \cdot 10^{17}$  and  $m=17$ .

# THE VOLTAGE HOLDING PREDICTIVE MODEL

Validation

## Results

- The Model overestimates the 63% the breakdown probability voltage (+14%)
- The Model predicts correctly the ratio between the two polarities (1.05)

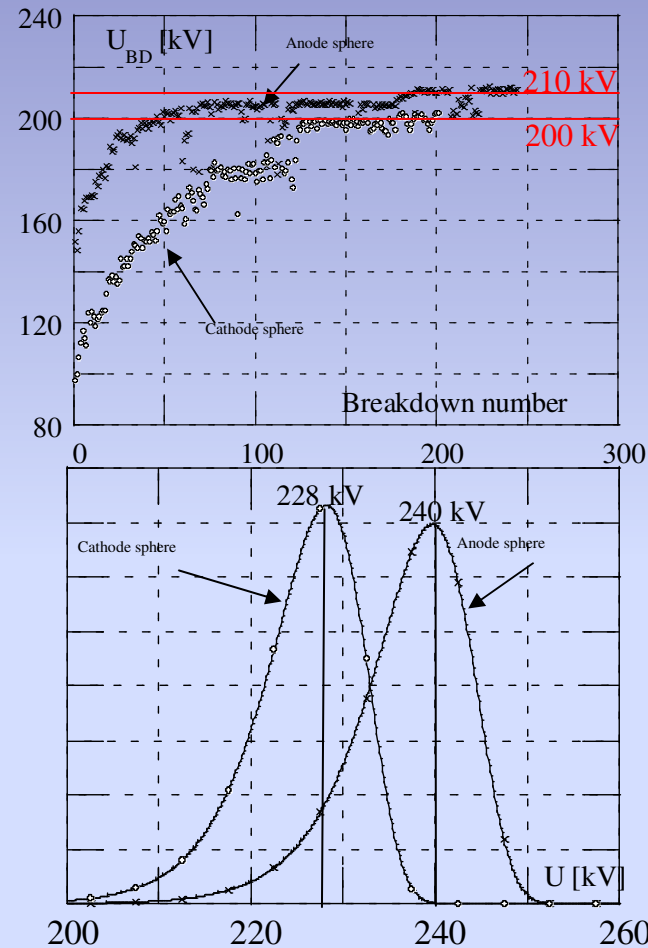

Experimental results and model prediction. The peak of the curve indicates the 63.2% breakdown probability.

# THE VOLTAGE HOLDING PREDICTIVE MODEL



Discussion

- Not fully satisfactory capability to predict the absolute value of the voltage breakdown.
  - $W_0$  and  $m$  measured values should be closer
  - $W_0$  deviation appears for long gaps (from literature)
  - Prediction should be more accurate
    - Problems encountered during the experiment (many stops and go)
    - Physical Basis (S&C model) not well consolidated
- Good prediction of the effects due to geometry changes
  - Polarity inversion (this campaign)
  - Results reported in previous work<sup>1</sup>
    - Correctness of the formulation: probabilistic approach and  
 $W = F(E_K, E_A, U)$

# THE VOLTAGE HOLDING PREDICTIVE MODEL

Comparison with the results obtained in changing the accelerator structure from Single Gap to Multi Gap at the Megavolt Test Facility at JAEA, Naka (JP)

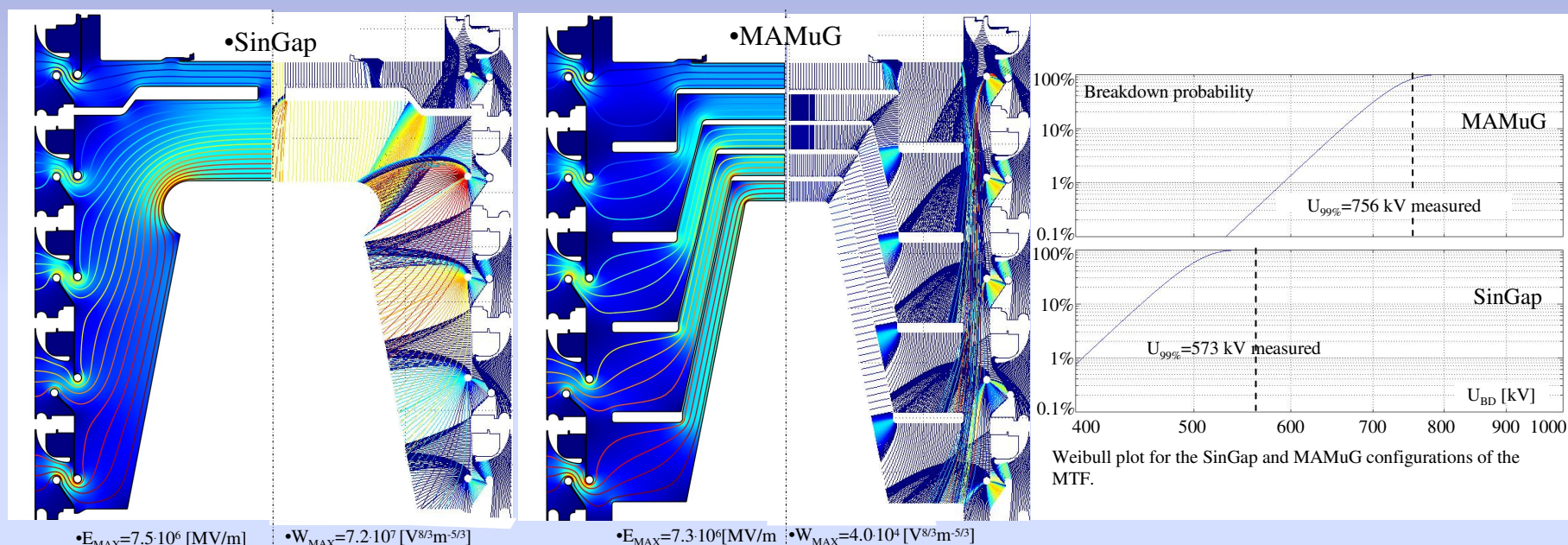

Comparison between the electrostatic field (left) and the particle trajectory (right) analyses for the two configurations.  
 $W_0 = 1.15 \cdot 10^{16}$

The Cranberg-Slivkov mechanism, does not collect unanimous consensus as main driver of breakdown over long ( $d > 10$  mm) gaps.

- Not well proven processes of continuous formation of the micro particles.
- Why only negative clumps (originated from cathode) produce the breakdown.

On the other hand, the breakdown condition  $W(E_K, E_A, U) > W_l$  shall be retained, because it accounts for the experimental evidence of the non linearity of the voltage breakdown against the gap length  $U \propto d^\alpha$ ,  $0.3 < \alpha < 0.8$ .

**An alternative breakdown mechanism not based on microparticles can be imagined ?**

# REVIEW OF THE MODEL PHYSICAL BASIS



The Photoelectric Cascade Model

The suggestion proposed by Latham, based on the FN electron emission from the cathode<sup>1</sup> has been analyzed.

Basically, the anode bombardment produced by the primary electrons carried by the FN current is not sufficient to stimulate ion emission from the anode, making possible the startup of an avalanche process.

But at the anode are produced -by primary electrons momentum transfer- secondary electrons; these, re-accelerated toward the anode, by the local electric field, emit soft X-ray, capable to stimulate cathode electrons emission: an avalanche process can start.

At the same time, the effect of the primary electrons is to create, on the anode surface, a charge separation layer, deploying electrons from the anode surface; an internal electric field  $E_i$ , opposite to the  $E_A$ , appears inside this layer; this process counteracts the production of secondary electrons, reducing the total electron current flowing from cathode to anode.

<sup>1</sup>R. Latham "High Voltage Vacuum Insulation, new perspective", AuthorHouse, UK, (2006)



# REVIEW OF THE MODEL PHYSICAL BASIS

The Photoelectric Cascade Model

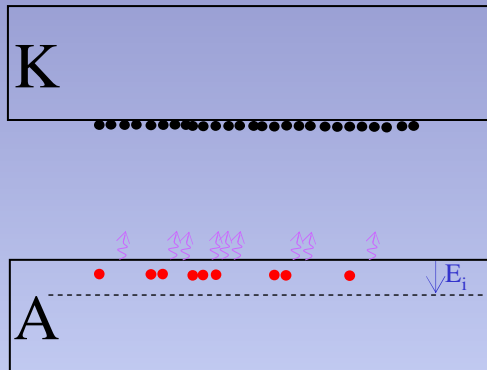

$I_R$  Actual electronic current:

$$I_R = I - I_d \quad I = \text{FN current plus the effect of Xray stimulation}$$

$I_d$  = current reduction due to  $E_i$  appearance

**Breakdown condition**

$$\Delta I_R > 0 \rightarrow \Delta I > \Delta I_d$$

The expression of  $\Delta I$  and  $\Delta I_R$  are derived as follows

## $\Delta I$ evaluation

$$\Gamma = \alpha \frac{I_{FN}}{e} ; I_{FN} = A \cdot E_K^2 \cdot e^{-\frac{B}{E_K}}$$

$$I' = \beta \cdot e \cdot \Gamma$$

$$\Delta I = I_{FN} \cdot \alpha \beta$$

Soft Xray flux produced by primary electrons at the anode

Electron current stimulated by the Soft Xray flux

Current increase after first  $2\tau$ ,  $\tau$  electron travelling time.

$\alpha\beta > 0$ : *BD necessary condition*

$\alpha\beta > 1$ : *BD sufficient condition*

## $\Delta I_d$ evaluation

$$E_i = \frac{e \cdot \Delta N \cdot S}{\epsilon_0}$$

Internal electric field caused by charge separation

$$\Delta I_d \propto e \cdot \Delta N$$

Current decrease proportional to charge separation after the first  $2\tau$



$$\Delta I_d = k \cdot E_i$$

## *Breakdown condition*

- Flux  $\Gamma$  proportional to the number of collisions of primary electrons that produce the secondary electrons
- the number of collisions is proportional to the penetration depth  $\delta$
- $\delta \propto U^m$  ( $m=2$  Whiddington;  $m=1.35$  Young;  $m=1.39$  Hakenberg)
- Some influence of  $E_A$  on soft X production (spatial distribution)
- The Electric field  $E_i$  is limited to a certain value  $E_{i-max}$

Similarity to Slivkov-Cranberg model;

$$\alpha\beta \propto F(E_A) \cdot U^m$$

For negligible dependence upon  $E_A$ , and  $m=2$  relationship  $U=kd^{0.5}$  is found

$$F(E_A) \cdot E_K^2 \cdot U^2 > k \cdot E_{i-max} = const$$

Use in the predictive model possible for  $U < \text{some hundreds of kV}$  (non relativistic electrons)

# CONCLUSIONS AND FUTURE WORK

- Fair results of the Voltage Holding Prediction Model, especially for geometry changes
- The breakdown variable  $W=W(E_A, E_K, U)$  appears to be a “good choice”
- If the the Photo-Electric Cascade model is the prevailing breakdown mechanism, the VHPM shall be modified to manage relativistic electrons
- Campaign focused to evaluate the effect of magnetic field on voltage holding would give indication about the prevailing breakdown process (clump or electrons)

*Thank You for Your Attention*